

FEATURES

- Hermetic package offers excellent long-term stability**
- 0 g offset vs. temperature (all axes): 0.75 mg/°C maximum**
- Ultralow noise density (all axes): 80 $\mu\text{g}/\sqrt{\text{Hz}}$**
- Low power, V_{SUPPLY} (LDO enabled)**
 - Measurement mode: 150 μA typical**
 - Standby mode: 21 μA typical**
- User adjustable analog output bandwidth**
- Integrated temperature sensor**
- Voltage range options**
 - V_{SUPPLY} with internal regulators: 2.25 V to 3.6 V**
 - $V_{1\text{P8ANA}}$, $V_{1\text{P8DIG}}$ with internal LDO regulator bypassed: 1.8 V typical $\pm 10\%$**
- 14-terminal, 6.0 mm \times 5.6 mm \times 2.05 mm, LCC package, 0.26 g**

ENHANCED PRODUCT FEATURES

- Supports defense and aerospace applications (AQEC standard)**
- Military temperature range: -55°C to $+125^{\circ}\text{C}$**
- Controlled manufacturing baseline**
- One assembly/test site**
- One fabrication site**
- Product change notification**
- Qualification data available on request**

APPLICATIONS

- Inertial measurement units (IMUs)/altitude and heading reference systems (AHRs)**
- Platform stabilization systems**
- Structural health monitoring**
- Seismic imaging**
- Tilt sensing**
- Robotics**
- Condition monitoring**

GENERAL DESCRIPTION

The ADXL356-EP is an analog output, low noise density, low 0 g offset drift, low power, 3-axis accelerometer with selectable measurement ranges. The ADXL356-EP supports the $\pm 10\text{ g}$ and $\pm 40\text{ g}$ ranges.

The ADXL356-EP offers industry leading noise, minimal offset drift over temperature, and long-term stability, enabling precision application with minimal calibration.

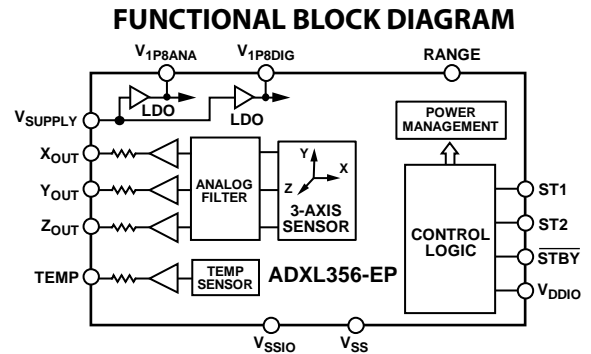

The low noise of the ADXL356-EP over higher frequencies is ideal for wireless condition monitoring.

Additional application and technical information can be found in the [ADXL356/ADXL357](#) data sheet.

¹ Protected by U.S. Patents 8,472,270; 9,041,462; 8,665,627; 8,917,099; 6,892,576; 9,297,825; and 7,956,621.

TABLE OF CONTENTS

Features	1	Thermal Resistance	5
Enhanced Product Features	1	ESD Caution.....	5
Applications.....	1	Pin Configuration and Function Descriptions.....	6
Functional Block Diagram	1	Typical Performance Characteristics	7
General Description	1	Outline Dimensions	9
Revision History	2	Ordering Guide	9
Specifications.....	3		
Absolute Maximum Ratings.....	5		

REVISION HISTORY

4/2018—Revision 0: Initial Release

SPECIFICATIONS

$T_A = 25^\circ\text{C}$, supply voltage (V_{SUPPLY}) = 3.3 V, x-axis acceleration and y-axis acceleration = 0 g, z-axis acceleration = 1 g, and full-scale range = ± 10 g, unless otherwise noted.

Table 1.

Parameter	Test Conditions/Comments	Min	Typ	Max	Unit
SENSOR INPUT					
Output Full-Scale Range (FSR)	Each axis Supports two ranges		$\pm 10/\pm 40$		g
Resonant Frequency ¹			5.5		kHz
Nonlinearity	± 10 g		0.1		%
Cross Axis Sensitivity			1		%
SENSITIVITY					
Sensitivity at X_{OUT} , Y_{OUT} , and Z_{OUT}	Ratiometric to $V_{1\text{P8ANA}}$ ± 10 g ± 40 g	73.6 18.4	80 20	86.4 21.6	mV/g mV/g
Sensitivity Change Due to Temperature	$T_A = -55^\circ\text{C}$ to $+125^\circ\text{C}$		± 0.01		%/ $^\circ\text{C}$
0 g OFFSET					
0 g Output for X_{OUT} , Y_{OUT} , and Z_{OUT}	Each axis, ± 10 g Referred to $V_{1\text{P8ANA}}/2$	-375	± 125	+375	mg
0 g Offset vs. Temperature (X-Axis, Y-Axis, and Z-Axis) ²	$T_A = -55^\circ\text{C}$ to $+125^\circ\text{C}$	-0.75	± 0.5	+0.75	mg/ $^\circ\text{C}$
Vibration Rectification Error (VRE) ³	Offset due to 7.5 g rms vibration, ± 10 g range, in a 1 g orientation		<0.1		g
NOISE DENSITY					
X-Axis, Y-Axis, and Z-Axis	± 10 g		80		$\mu\text{g}/\sqrt{\text{Hz}}$
Velocity Random Walk	X-axis and y-axis Z-axis		45 65		$\mu\text{m}/\text{sec}/\sqrt{\text{Hr}}$ $\mu\text{m}/\text{sec}/\sqrt{\text{Hr}}$
BANDWIDTH					
Internal Low-Pass Filter Frequency	Fixed frequency, 50% response attenuation		1500		Hz
SELF TEST					
Output Change Z-Axis	± 10 g range		1.25		g
POWER SUPPLY					
Voltage Range					
V_{SUPPLY} ⁴		2.25	2.5	3.6	V
Digital Interface Supply Voltage (V_{DDIO})		$V_{1\text{P8DIG}}$	2.5	3.6	V
Analog Supply ($V_{1\text{P8ANA}}$), Digital Supply ($V_{1\text{P8DIG}}$) with Internal Low Dropout (LDO) Regulator Bypassed	$V_{\text{SUPPLY}} = 0$ V	1.62	1.8	1.98	V
Current					
Measurement Mode					
V_{SUPPLY} (LDO Enabled)			150		μA
$V_{1\text{P8ANA}}$ (LDO Disabled)			138		μA
$V_{1\text{P8DIG}}$ (LDO Disabled)			12		μA
Standby Mode					
V_{SUPPLY} (LDO Enabled)			21		μA
$V_{1\text{P8ANA}}$ (LDO Disabled)			7		μA
$V_{1\text{P8DIG}}$ (LDO Disabled)			10		μA
Turn On Time ⁵	10 g range Power-off to standby		<10 <10		ms ms
OUTPUT AMPLIFIER					
Swing	No load	0.03		$V_{1\text{P8ANA}} - 0.03$	V
Output Series Resistance			32		k Ω

Parameter	Test Conditions/Comments	Min	Typ	Max	Unit
TEMPERATURE SENSOR					
Output at 25°C			963.3		mV
Scale Factor			3.0		mV/°C
TEMPERATURE					
Operating Temperature Range		-55		+125	°C

¹ The resonant frequency is a sensor characteristic. An integrated analog 1.5 kHz (-6 dB) sinc low-pass filter that cannot be bypassed limits the actual output response.

² The temperature change is -55°C to +25°C or +25°C to +125°C.

³ The VRE measurement is the shift in dc offset while the device is subject to 12.5 g rms of random vibration from 50 Hz to 2 kHz. The device under test (DUT) is configured for the ±10 g range and an output data rate of 4 kHz. The VRE scales with the range setting.

⁴ When V_{1PBANA} and V_{1PBDIG} are generated internally, V_{SUPPLY} is valid. To disable the LDO and drive V_{1PBANA} and V_{1PBDIG} externally, connect V_{SUPPLY} to V_{SS}.

⁵ Standby to measurement mode; valid when the output is within 5 mg of the final value.

ABSOLUTE MAXIMUM RATINGS

Table 2.

Parameter	Rating
Acceleration (Any Axis, 0.1 ms)	5000 <i>g</i>
V _{SUPPLY} , V _{DDIO}	5.4 V
V _{1P8ANA} , V _{1P8DIG} Configured as Inputs	1.98 V
Digital Inputs (RANGE, ST1, ST2, STBY)	−0.3 V to V _{DDIO} + 0.3 V
Analog Outputs (X _{OUT} , Y _{OUT} , Z _{OUT} , TEMP)	−0.3 V to V _{1P8ANA} + 0.3 V
Operating Temperature Range	−55°C to +125°C
Storage Temperature Range	−65°C to +150°C

Stresses at or above those listed under Absolute Maximum Ratings may cause permanent damage to the product. This is a stress rating only; functional operation of the product at these or any other conditions above those indicated in the operational section of this specification is not implied. Operation beyond the maximum operating conditions for extended periods may affect product reliability.

THERMAL RESISTANCE

Thermal performance is directly linked to printed circuit board (PCB) design and operating environment. Careful attention to PCB thermal design is required.

θ_{JA} is the natural convection junction to ambient thermal resistance measured in a one cubic foot sealed enclosure.

Table 3. Thermal Resistance

Package Type	θ_{JA}	Unit
E-14-1 ¹	42	°C/W

¹ Thermal impedance simulated values are based on a JEDEC 252P thermal test board with four thermal vias. See JEDEC JESD51.

ESD CAUTION



ESD (electrostatic discharge) sensitive device. Charged devices and circuit boards can discharge without detection. Although this product features patented or proprietary protection circuitry, damage may occur on devices subjected to high energy ESD. Therefore, proper ESD precautions should be taken to avoid performance degradation or loss of functionality.

PIN CONFIGURATION AND FUNCTION DESCRIPTIONS

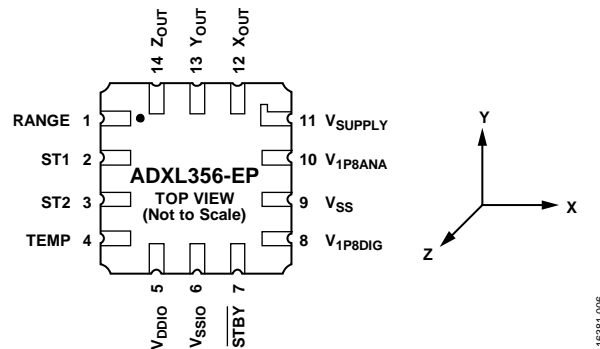

Figure 2. Pin Configuration

Table 4. Pin Function Descriptions

Pin No.	Mnemonic	Description
1	RANGE	Range Selection Pin. Set this pin to ground to select the $\pm 10 g$ range, or set RANGE to V_{DDIO} to select the $\pm 40 g$ range.
2	ST1	Self Test Pin 1. This pin enables self test mode.
3	ST2	Self Test Pin 2. This pin activates the electromechanical self test actuation.
4	TEMP	Temperature Sensor Output.
5	V_{DDIO}	Digital Interface Supply Voltage.
6	V_{SSIO}	Digital Ground.
7	\overline{STBY}	Standby or Measurement Mode Selection Pin. Set \overline{STBY} to ground to enter standby mode, or set \overline{STBY} to V_{DDIO} to enter measurement mode.
8	V_{1P8DIG}	Digital Supply. This pin requires a decoupling capacitor. If V_{SUPPLY} connects to V_{SS} , supply the voltage to this pin externally.
9	V_{SS}	Analog Ground.
10	V_{1P8ANA}	Analog Supply. This pin requires a decoupling capacitor. If V_{SUPPLY} connects to V_{SS} , supply the voltage to this pin externally.
11	V_{SUPPLY}	Supply Voltage. When V_{SUPPLY} equals 2.25 V to 3.6 V, V_{SUPPLY} enables the internal LDO regulators to generate V_{1P8DIG} and V_{1P8ANA} . For $V_{SUPPLY} = V_{SS}$, V_{1P8DIG} and V_{1P8ANA} are externally supplied.
12	X_{OUT}	X-Axis Output.
13	Y_{OUT}	Y-Axis Output.
14	Z_{OUT}	Z-Axis Output.

TYPICAL PERFORMANCE CHARACTERISTICS

All figures include data for multiple devices and multiple lots, and they were taken in the ± 10 g range, unless otherwise noted.

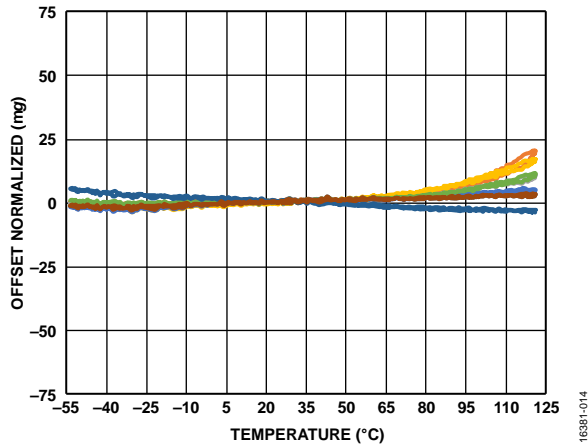

Figure 3. X-Axis Zero g Offset Normalized Relative to 25°C vs. Temperature for Multiple Devices

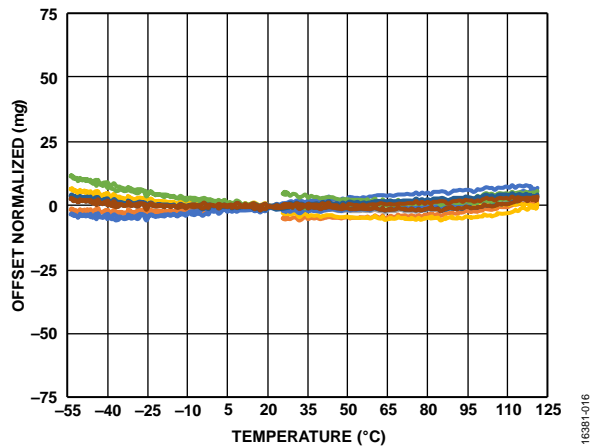

Figure 5. Z-Axis Zero g Offset Normalized Relative to 25°C vs. Temperature for Multiple Devices

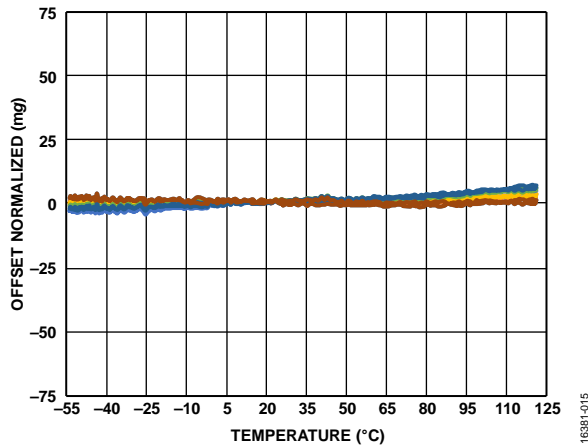

Figure 4. Y-Axis Zero g Offset Normalized Relative to 25°C vs. Temperature for Multiple Devices

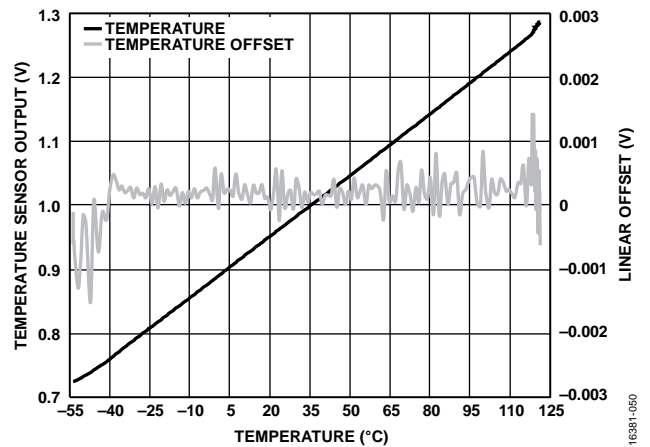
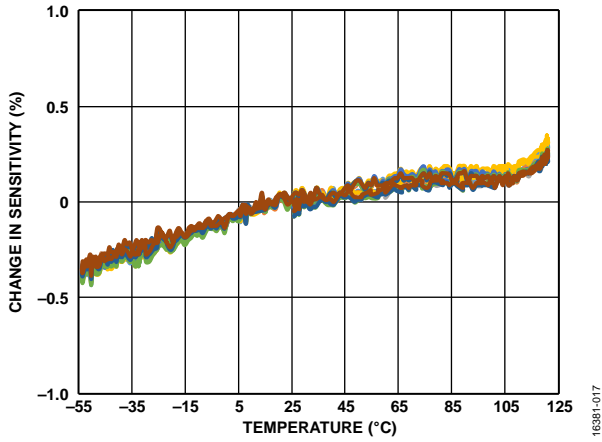
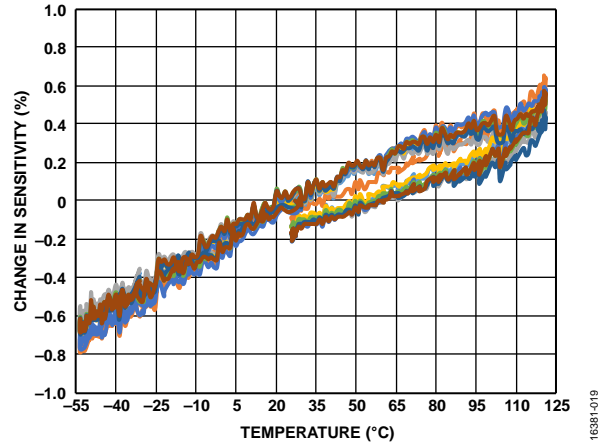

Figure 6. Temperature Sensor Output and Linear Offset vs. Temperature for Multiple Devices



16381-017

Figure 7. X-Axis Change in Sensitivity Relative to 25°C vs. Temperature for Multiple Devices



16381-019

Figure 9. Z-Axis Change in Sensitivity Relative to 25°C vs. Temperature for Multiple Devices

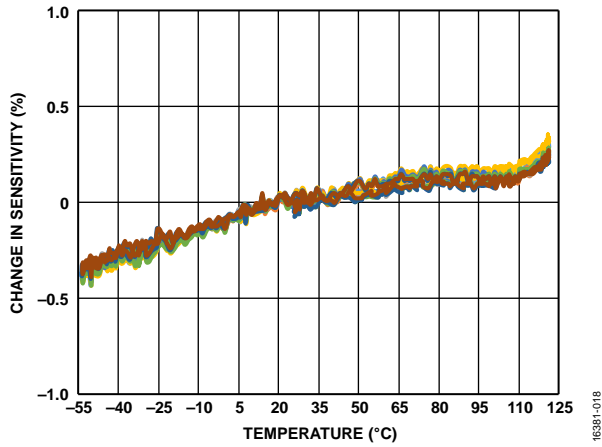

16381-018

Figure 8. Y-Axis Change in Sensitivity Relative to 25°C vs. Temperature for Multiple Devices

OUTLINE DIMENSIONS

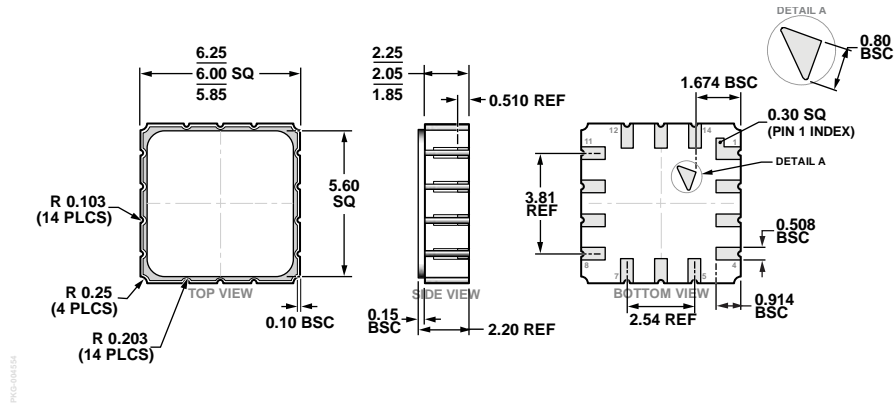

Figure 10. 14-Terminal Ceramic Leadless Chip Carrier [LCC]
(E-14-1)
Dimensions shown in millimeters

ORDERING GUIDE

Model ¹	Output Mode	Measurement Range (g)	Specified Voltage (V)	Temperature Range	Package Description	Package Option
ADXL356TEZ-EP	Analog	±10, ±40	3.3	-55°C to +125°C	14-Terminal LCC	E-14-1
ADXL356TEZ-EP-RL	Analog	±10, ±40	3.3	-55°C to +125°C	14-Terminal LCC, 13" Reel	E-14-1
ADXL356TEZ-EP-RL7	Analog	±10, ±40	3.3	-55°C to +125°C	14-Terminal LCC, 7" Reel	E-14-1

¹ Z = RoHS Compliant Part.